

Application Note

Series & Parallel Impedance Parameters and Equivalent Circuits

At any specific frequency, an impedance may be represented by either a series or a parallel combination of an ideal resistive element and an ideal reactive element, which is either capacitive or inductive (as illustrated in Figure 1). Such a representation is called an equivalent circuit. The values of these elements or parameters depend on which representation is used, series or parallel, except when the impedance is purely resistive or purely reactive. In such cases only one element is necessary and the series or parallel values are the same. The relationships between the values of these parameters are given in Table 1 where the subscript s indicates a series value and the subscript p indicates a parallel one. These formulas make use of two quantities: the dissipation factor, D , which is the ratio of the resistance of an impedance to its reactance, and the quality factor, Q , which is the reciprocal of D . It should be emphasized that these series and parallel equivalent circuits both have the same value of complex impedance at a single frequency, but at any other frequency their impedances will be different. (Example in Figure 2)

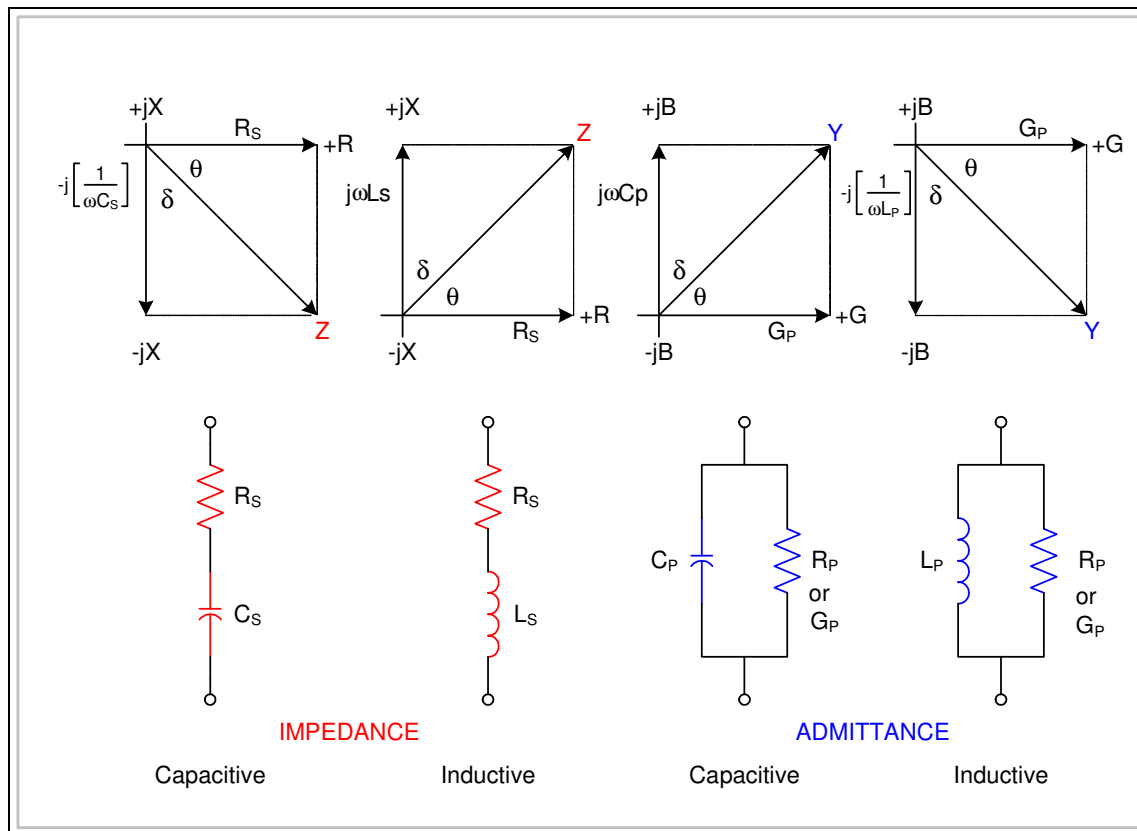

Figure 1: Equivalent Circuits & Phase Relationships



Application Note

Complex impedance and admittance

For dc, the resistance, R , of a linear device is defined by Ohm's Law as the ratio of the voltage applied across the device to the resulting current through it.

$$R = \frac{E}{I} \quad \text{Ohm's Law} \quad (1)$$

Resistance, R , can be specified by a single real number and the unit is the Ohm (Ω). The conductance, G , of a device is the reciprocal of its resistance: $G = 1/R$. The unit of conductance is the siemen (formerly mho, 'ohm' spelled backwards).

For ac, the ratio of voltage to current is a complex number because ac voltages and currents have phase as well as magnitude. This complex number is called impedance, Z , and is the sum of a real number, R , and an imaginary one, jX , (where $j = \sqrt{-1}$). Thus, $Z = R + jX$. The real part is the ac resistance and the imaginary part is the reactance. Both have units of Ohms (Ω).

Reactances come in two types, inductive and capacitive. The reactance of an inductive element is ωL , where L is its inductance and $\omega = 2\pi f$ (where f = frequency). The reactance of a capacitive element is negative, $-1/\omega C$, where C is its capacitance. The negative sign occurs because the impedance of a pure capacitor is $1/j\omega C$ and $1/j = -j$.

Because the impedance of two devices in series is the sum of their separate impedances, we can think of an impedance as being the series combination of an ideal resistor and an ideal capacitor or inductor. This is the series equivalent circuit of an impedance comprising an equivalent series resistance and an equivalent series capacitance or inductance (see Figure 1). Using the subscript s for series, we have:

$$Z = R_s + jX_s = R_s + j\omega L \text{ or } R_s - j/\omega C \quad (2)$$

For a complicated network having many components, it is obvious that the element values of the equivalent circuit will change as the frequency is changed. This is also true of the values of both the elements of the equivalent circuit of a single, actual component, although the changes may be very small.

Admittance, Y , is the reciprocal of impedance,

$$Y = \frac{1}{Z} \quad (3)$$

It too is complex, having a real part, the ac conductance G , and an imaginary part, the susceptance B . Because the admittances of parallel elements are additive, Y can be represented by a parallel



Application Note

combination of an ideal conductance and a susceptance, where the latter is either an ideal capacitance or an ideal inductance (see Figure 1).

More complex numbers

Using the subscript p for parallel elements, we have:

$$Y = G_P + jB_P = G_P + j\omega C_P \text{ or } G_P - j/\omega L \quad (4)$$

Note that an inductance susceptance is negative and also note the similarity or duality of this last equation and Equation 2.

It is important to recognize that, in general, G_P is not equal to $1/R_S$ and B_P is not equal to $1/X_S$ (or $-1/X_S$) as one can see from the following calculation.

$$Y = \frac{1}{Z} = \frac{1}{R_S + jX_S} = \frac{R_S}{R_S^2 + X_S^2} - j \frac{X_S}{R_S^2 + X_S^2} = G_P + jB_P \quad (5)$$

Thus $G_P = 1/R_S$ only if $X_S = 0$, which is the case only if the impedance is a pure resistance, and $B_P = -1/X_S$ (note the minus sign) only if $R_S = 0$, that is, the impedance is a pure capacitance or inductance.

G_P , C_P and L_P are the equivalent parallel parameters. Because a pure resistance is the reciprocal of a pure conductance and has the same symbol, we can use R_P instead of G_P for the resistor symbols in Figure 1, noting that $R_P = 1/G_P$ and R_P is the equivalent parallel resistance. (By analogy, the reciprocal of the series resistance, R_S , is series conductance, G_S , but this quantity is rarely used).

Two other quantities, D and Q , are useful, not only to simplify the conversion formulas of Figure 1, but also by themselves, as measures of the "purity" of a component, that is, how close it is to being ideal or containing only resistance or reactance. D , the dissipation factor, is the ratio of the real part of impedance, or admittance, to the imaginary part, and Q , the quality factor, is the reciprocal of this ratio.

$$D = \frac{R_S}{X_S} = \frac{G_P}{B_P} = \frac{1}{Q} \quad (6)$$

A low D value, or high Q , means that a capacitor or inductor is quite pure, while a low Q , or high D , means that a resistor is nearly pure. (In Europe, instead of D they use the tangent of the angle delta, $\tan \delta$. See Figure 1 and Equation 14).



Application Note

Some conventions are necessary as to the signs of D or Q. For capacitors and inductors, D and Q are considered to be positive as long as the real part of Z or Y is positive, as it will be for passive components. (Note, however, that transfer impedance of passive networks can exhibit negative real parts). For resistors, a common convention is to consider Q to be positive if the component is inductive (having a positive reactance), and to be negative if it is capacitive (having a negative reactance).

Complex Equations: You do the math!

Formulas for D and Q in terms of the series and parallel parameters are given in Table 1. D or Q are independent of the configuration of the equivalent circuit used to represent the impedance.

Table 1: Impedance Equations

Parameter	Quantity	Unit Symbol	Formula
Z	Impedance	ohm, Ω	$Z = R_S + jX_S = \frac{1}{Y} = Z \varepsilon^{j\theta}$
Z	Magnitude of Z	ohm, Ω	$ Z = \sqrt{R_S^2 + X_S^2} = \frac{1}{ Y }$
R_S or ESR	Resistance, Real part of Z	ohm, Ω	$R_S = \frac{G_P}{G_P^2 + B_P^2} = \frac{R_P}{1 + Q^2}$
X_S	Reactance, Imaginary part of Z	ohm, Ω	$X_S = -\frac{B_P}{G_P^2 + B_P^2}$
Y	Admittance	siemen, S	$Y = G_P + jB_P = \frac{1}{Z} = Y \varepsilon^{j\phi}$
Y	Magnitude of Y	siemen, S (was mho)	$ Y = \sqrt{G_P^2 + B_P^2} = \frac{1}{ Z }$
G_P	Real part of Y	siemen, S	$G_P = \frac{R_S}{R_S^2 + X_S^2}$
B_P	Susceptance	siemen, S	$B_P = -\frac{X_S}{R_S^2 + X_S^2}$
C_S	Series capacitance	farad, F	$C_S = -\frac{1}{\omega X_S} = C_P (1 + D^2)$
C_P	Parallel capacitance	farad, F	$C_P = \frac{B}{\omega} = \frac{C_S}{1 + D^2}$
L_S	Series inductance	henry, H	$L_S = \frac{X}{\omega} = L_P \frac{Q^2}{1 + Q^2}$
L_P	Parallel inductance	henry, H	$L_P = -\frac{1}{\omega B_P} = L_S (1 + \frac{1}{Q^2})$
R_P	Parallel resistance	ohm, Ω	$R_P = \frac{1}{G_P} = R_S (1 + Q^2)$



Application Note

Q	Quality factor	none	$Q = -\frac{1}{D} = \frac{X_s}{R_s} = \frac{G_p}{B_p} = \tan \theta$
D, DF or $\tan \delta$	Dissipation factor	none	$D = -\frac{1}{Q} = \frac{R_s}{X_s} = \frac{B_p}{G_p} = \tan(90^\circ - \theta) = \tan \delta$
θ	Phase angle of Z	degree or radian	$\theta = -\phi$
ϕ	Phase angle of Y	degree or radian	$\phi = -\theta$

Notes: f = frequency in Hertz, $j = \sqrt{-1}$, $\omega = 2\pi f$

R and X are equivalent **series** quantities unless otherwise defined. G and B are equivalent **parallel** quantities unless otherwise defined.

We sometimes use parallel R (R_p) but rarely use parallel X, and very rarely series G or series B.

C and L each have two values, series and parallel. If not defined usually we mean the series values, but not necessarily, especially for C (C_p is common, L_p is less used).

We define Q as being positive if it is inductive, negative if it is capacitive, We define D as positive if capacitive.

Thus $D = -1/Q$.

Some people (particularly in Europe) use $\tan \delta$ instead of D, $\tan \delta = D$.

Polar Form: Magnitude and phase

A complex number may be expressed in polar form as well as in the Cartesian form used so far. For impedance and admittance the relationships are

$$Z = R_s + jX_s = |Z|e^{j\theta} \quad \text{and} \quad Y = G_p + jB_p = |Y|e^{j\phi} \quad (7)$$

where $|Z|$ and $|Y|$ are the magnitudes and that θ (theta) and ϕ (phi) are the phase angles in radians. The magnitude of a complex number is the square root of the sum of the squares of the two parts so that

$$|Z| = \sqrt{R_s^2 + X_s^2} \quad \text{and} \quad |Y| = \sqrt{G_p^2 + B_p^2} \quad (8)$$

Note that $|Z| = 1/|Y|$. This can be checked using the calculation of Equation 5.

The phase angle of an impedance or an admittance is the angle whose tangent is the ratio of the imaginary part to the real part so that

$$\theta = \arctan (X/R) = \arctan Q, \quad \text{or} \quad \tan \theta = Q \quad (9)$$

$$\text{and} \quad \phi = \arctan (G/B) = \arctan Q, \quad \text{or} \quad \tan \phi = Q \quad (10)$$

The size of the phase angle of an admittance is the same as that of the corresponding impedance. Yet if we use the convention that a positive angle is one in the counterclockwise direction then the angle of an admittance is the negative of that of the corresponding impedance, as one can see from the equation:



Application Note

$$Y = \frac{1}{Z} = \frac{1}{|Z|e^{j\theta}} = \frac{Y}{e^{j\theta}} = |Y|e^{-j\theta} = |Y|e^{j\phi} \quad (11)$$

$$\text{Euler's formula, } e^{jx} = \cos x + j \sin x, \quad (12)$$

is useful when dealing with imaginary exponents and can be used to show that

$$R_s = |Z|\cos \theta, \text{ and that } X_s = |Z|\sin \theta \quad (13)$$

These phase relationships can be understood better using the diagrams of Figure 1 which show both inductive and capacitive impedance phasors (or planar vectors) on both the Z and Y planes. Here the angle is measured from the positive real axis (+R or + G) and the angle δ (delta) is defined as the compliment of θ or ϕ so one can see that:

$$\text{tangent } \delta = \text{cotangent } \theta = \frac{R_s}{X_s} = \frac{B_p}{G_p} = D \quad (14)$$

Frequently asked questions

1. Which should be measured series or parallel parameters?

It depends on the **purpose of the measurement**. For incoming inspection and production measurements on passive components usually the series values is specified in EIA and MIL standards. These standards also specify test frequencies and other test conditions and should be consulted.

If one is trying to determine the dc value of a resistor using ac measurements it is best to make series measurements of low-valued resistors (say under 1 k Ω) and to make parallel measurements of high-valued ones. In most cases this almost completely avoids errors due to series inductance and parallel lumped capacitance. Also, a low frequency should be used. Note that sometimes an ac measurement can give the correct dc value better than a dc measurement because thermal voltage and drift errors are avoided and measurement sensitivity is apt to be higher.

Other cases where parallel measurements are preferred are when measuring very low values of capacitance, when making measurements on dielectric and magnetic materials, and, of course, when trying to determine the separate values of two components in parallel. Very often the D of a capacitor is less than .01 so that it doesn't make any difference which is measured because the difference between



Application Note

the series and parallel values is less than .01%. Likewise, the Q of a resistor is usually less than .01 so that either resistance quantity can be measured.

2. Which equivalent circuit more closely models the behavior of a component?

Generally a series equivalent circuit is a better model of a low-impedance circuit and a parallel equivalent circuit better models a high-impedance one. However, all physical components are, in effect, complicated networks containing resistance, capacitance and inductance. The best model should be the one whose parameter values change least as the frequency is changed in the range being used.

3. What is the ESR of a capacitor?

ESR stands for equivalent series resistance, the same quantity that we call R_s in the above discussion. ESR is a measure of the loss in a capacitor and is related to D by:

$$\text{ESR} = R_s = D/\omega C_s \quad (\text{see Table 1})$$

One should note that ESR is not equal to the resistance that is actually in series with a capacitor, such as the resistance of the connections or in the foil or plate structure. It is a measure of the total loss in a capacitor which includes dielectric loss and loss in leakage resistance as well as loss in this actual series resistance. When the frequency is high or the capacitance is high, or both, the ESR often will approximate the actual series resistance because this resistance becomes the largest cause of loss under these conditions. However, ESR is always larger than this actual series resistance.

More FAQ's

4. What is Power Factor?

Power factor, PF, is defined as the cosine of the angle θ :

$$\text{PF} = \cos \theta = \frac{R}{|Z|} = \frac{D}{\sqrt{1+D^2}}$$

PF is used to calculate the power in a circuit using:

$$\text{Power} = I^2 R_s = I^2 |Z| \cos \theta = IE \cos \theta = IE(\text{PF})$$

where I and E are rms (root-mean-square) values.

5. What is Percent D?



IET LABS, INC.

www.ietlabs.com

TEL: (516) 334-5959 • (800) 899-8438 • FAX: (516) 334-5988

Application Note

D is sometimes expressed as a percent instead of as a decimal fraction and this has led to some confusion. As with any other number, to get percent one multiplies the number by 100 and adds the % sign. For example, a D of .01 is a D of 1%.

There is a problem in using D in % when one tries to express measurement accuracy. For example, if the measured value of D is express as 1% and the tolerance is given as .1%, what is the possible range of D values? Is it .01 +/- .001 (which is 1% +/- .1%) or is it .01 +/- .000 01 (which is 1% +/- .1% of 1%)? A percent tolerance of a quantity in percent can be ambiguous.

6. What is the ESL of a capacitor?

ESL, or equivalent series inductance, is a term that, unfortunately, is sometimes used to indicate the actual inductance in series with a capacitor (inductance in the leads, foils or plates). It would be preferable to simply refer to this as the inductance of a capacitor.

To be precise, equivalent series inductance is L_s in the above discussion and is the reactance divided by ω (see Equation 2). The reactance of a capacitor below resonance is negative L_s . Above resonance L_s is positive. If a capacitor can be modeled as a pure inductance, L , in series with a pure capacitance, C , then:

$$L_s = \frac{X}{\omega} = L - \frac{1}{\omega^2 C}$$

At a high enough frequency L_s will be nearly equal to L .

Example

Figure 2 illustrates the series and parallel equivalent circuits that have the identical impedance equal to 1000Ω at the specific frequency equal to $10/2\pi$ kHz (1.5915 kHz). If the frequency changes, the value

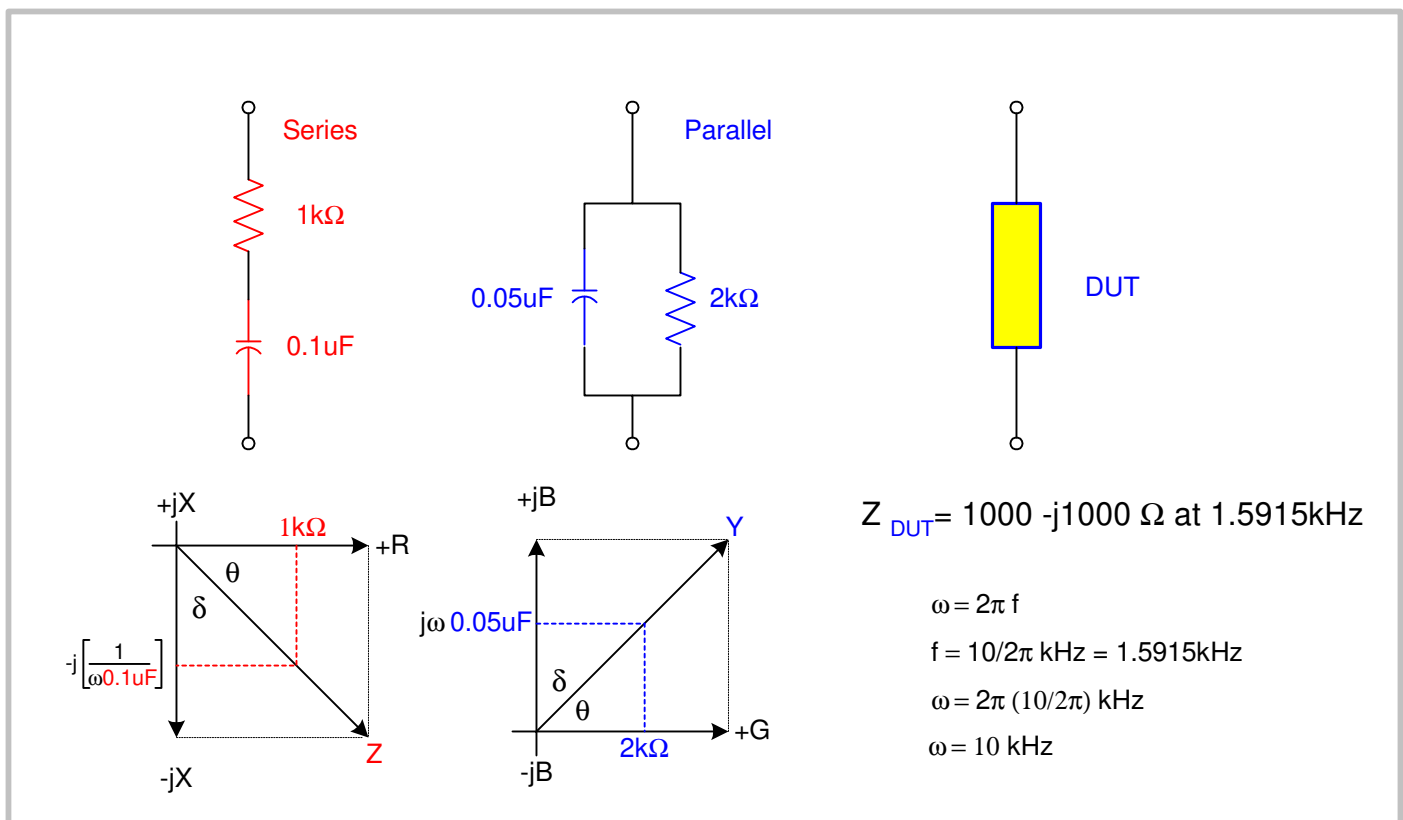

Application Note

of Z_{DUT} will change too.

Figure 2: Impedance of series & parallel circuits at a given frequency

Summary

No matter how it is expressed, in polar or Cartesian coordinates, as an impedance or an admittance, two quantities are required to specify an impedance (or admittance) value completely at any given frequency: R_s and X_s , G_p and B_p , $|Z|$ and θ or $|Y|$ and ϕ . Therefore to make a circuit diagram that represents an impedance at a given frequency one needs to use two circuit elements. These can be connected in two ways, series or parallel. The values of these circuit elements depend on which connection is used, and all these values change if the frequency is changed.

